

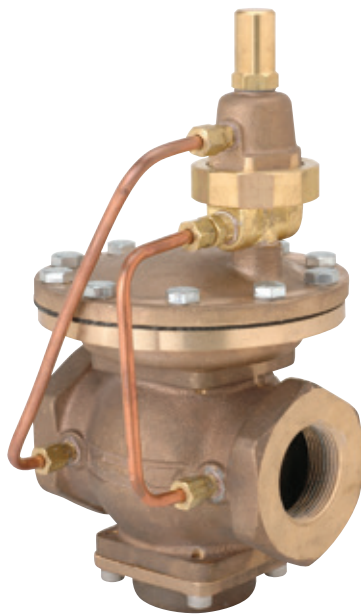

CASH VALVE TYPE KP BACK PRESSURE VALVES

A high capacity pilot operated back pressure valve that offers accurate control and dependable protection against overpressure conditions



FEATURES

- Automatically maintains maximum pressure in a vessel or system by relieving overpressure into a lower pressure return line or to atmosphere.
- Soft rubber seat allows tight shut-off under no-flow conditions.
- Available with factory modifications for systems with temperatures to 400°F (204°C)* and pressure to 400 psig (27.6 barg).
- Pilot system can be removed as one unit for easy servicing.
- Choice of 15-65 psig (1-4.5 barg) and 50-200 psig (3.4-13.8 barg) adjustment ranges. Special hi-pressure range from 200-400 psig (13.8-27.6 barg) also available.
- Maximum overpressure on standard spring ranges up to 300 psig (20.7 barg); 500 psig (34.4 barg) on hi-pressure range.

* The high temperature version must not be used on water applications that will flash to steam on the downstream side of the valve.

GENERAL APPLICATION

Designed for various gases or water service in systems where accurate control must be maintained, especially when high capacity flows are required. Typically for pump or test system by-pass and pressure vessel control applications.

TECHNICAL DATA

Materials:	Brass
Sizes:	1", 1¼", 1½", 2" (25, 32, 38, 50 mm)
Connections:	Threaded NPTF
Pressure range:	15 to 200 psig (1 to 13.8 barg)
Max. temperature:	160°F (71°C)

CASH VALVE TYPE KP BACK PRESSURE VALVES

MODEL OVERVIEW

The KP water valve has an inlet pressure connection to the pilot valve as well as a connection from the pilot valve's upper spring chamber to the valve outlet or downstream line. A fixed bleed orifice in the pilot valve spring chamber allows water pressure from the upper spring chamber to bleed downstream. However, downstream pressure in excess of 5 psi (0.34 barg) could affect valve performance. In this case the pilot bleed line should be piped to an open drain.

The KP air model is similar to the water valve except that the pressure in the spring chamber bleeds directly to atmosphere rather than to the downstream line.

OPERATION

Initially, both the main valve plug (A) and the pilot valve seat disc (B) are in a closed position. Both will remain closed until the inlet pressure approaches the valve's pressure setting.

When pressure is introduced at the main valve inlet it is also directed through the copper tube (C) to the pilot valve diaphragm chamber (D). The pressure required to open the pilot valve seat disc is determined by the pressure setting of the pilot spring (E). When the inlet pressure in the diaphragm chamber (D) is greater than the pressure setting, the seat disc opens. Pressure then passes from the pilot valve diaphragm chamber through the seat ring and into the main valve diaphragm chamber (F). Pressure also passes through the seat disc orifice (K) into the pilot valve spring chamber (G), where it is vented downstream through the pilot valve orifice (H) and the copper tube (I), (or to atmosphere in air service where normally no tube is required). When pressure in the main valve diaphragm chamber exceeds the upward force of the main valve piston spring (J), the main valve plug opens and allows flow through the valve.

When the inlet pressure drops below the pressure setting of the valve, the pilot spring forces the seat disc to close. Pressure in the main valve diaphragm chamber now bleeds through the seat disc orifice into the spring chamber and then downstream on water valves or into the atmosphere on air models. As pressure drops in the main valve diaphragm chamber, the main valve piston spring forces the main valve plug to close. As the seat is a rubber material, the valve is now tightly shut-off.

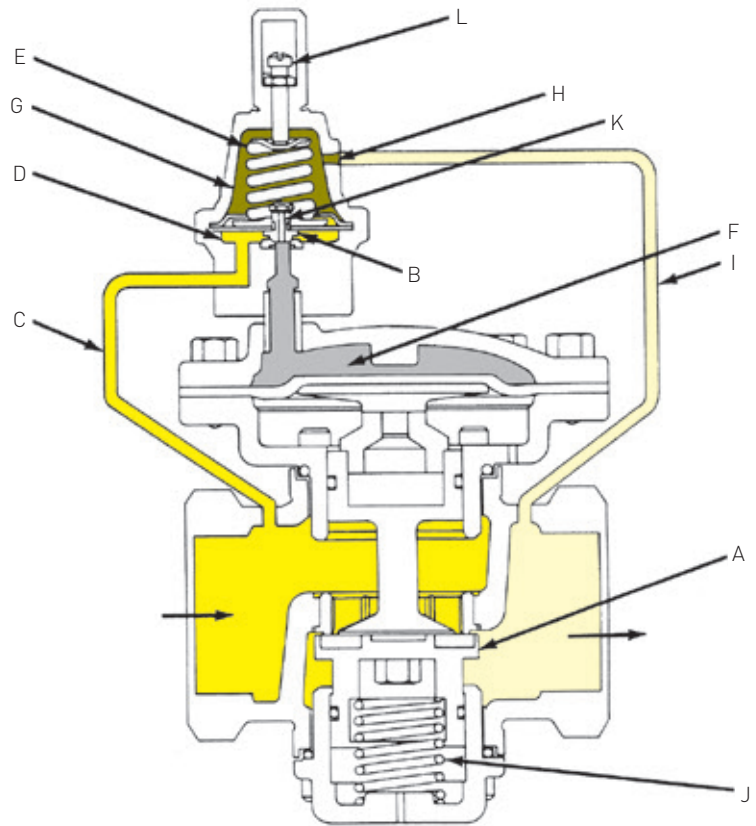

SCHEMATIC ILLUSTRATION TYPE KP

In normal operation, the pilot valve modulates the pressure in the diaphragm chamber to control the main valve plug opening. This regulates the fluid flow and maintains the pressure control on the system under varying pressure and flow conditions.

CASH VALVE TYPE KP BACK PRESSURE VALVES

KP HIGH CAPACITY PILOT OPERATED BACK PRESSURE VALVE

Construction

The Type KP main valve is fitted with a brass body, diaphragm case and stem; NBR diaphragm and seat disc and a stainless steel spring. The pilot valve has a brass body and spring chamber; a stainless steel spring, seat disc and seat ring with bronze diaphragms for air service or a neoprene diaphragm for water applications.

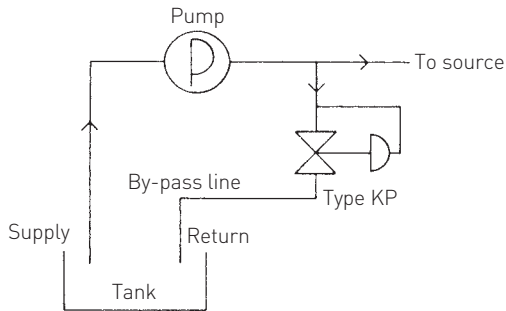

Pump by-pass - Type KP will serve as a highly accurate, high capacity pump by-pass valve.

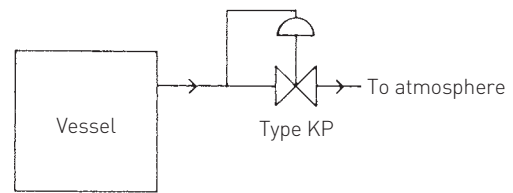

Back pressure relief - the KP can be used as an in-line back pressure relief valve where both accuracy and high capacity are required.

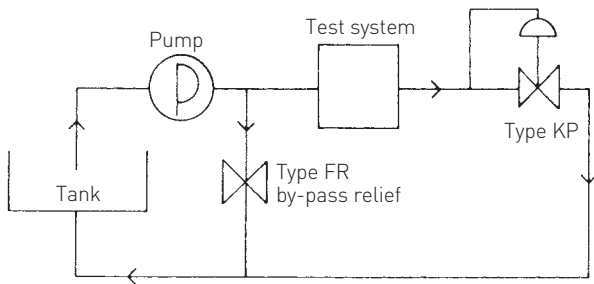

Test system by-pass - an FR Series or similar by-pass valve will function as a by-pass pressure control with the KP used as an in-line back pressure control to maintain the system's discharge pressure.

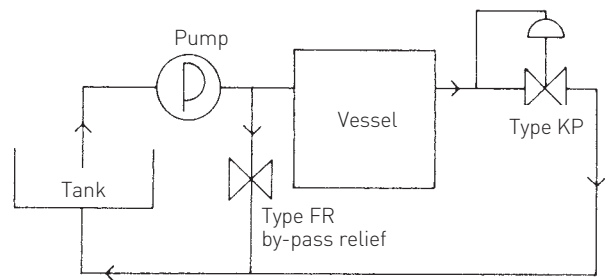

Pressure vessel control - in this example, a standard back pressure valve serves as a by-pass pressure valve and the KP controls the outlet pressure from a vessel or container.

TYPICAL INSTALLATIONS

CASH VALVE TYPE KP BACK PRESSURE VALVES

SPECIFICATIONS

Size	Adjustment range (psi)	Maximum valve overpressure*
All sizes	15-65	100 psi
	50-200	300 psi

Note: Type KP is also available for pressure settings from 200 to 300 psi; consult factory for details.

* Maximum valve overpressure is defined as the maximum pressure a valve can sustain without internal damage.

Size	Service	Dimensions				Shipping weight (lbs.)
		A	B	C	D	
1"	*	6 ³ / ₄ "	2 ⁷ / ₈ "	3 ¹ / ₈ "	4 ¹ / ₂ "	8 ¹ / ₄
	**	7 ⁷ / ₈ "	2 ⁷ / ₈ "	3 ¹ / ₂ "	4 ¹ / ₂ "	8 ³ / ₄
1 ¹ / ₄ "	*	6 ³ / ₄ "	2 ⁷ / ₈ "	3 ³ / ₈ "	4 ¹ / ₂ "	8 ¹ / ₄
	**	7 ⁷ / ₈ "	2 ⁷ / ₈ "	3 ¹ / ₂ "	4 ¹ / ₂ "	8 ³ / ₄
1 ¹ / ₂ "	*	7 ¹ / ₄ "	2 ¹⁵ / ₁₆ "	3 ¹⁵ / ₁₆ "	5 ³ / ₄ "	20 ¹ / ₄
	**	8 ³ / ₈ "	2 ¹⁵ / ₁₆ "	3 ¹⁵ / ₁₆ "	5 ³ / ₄ "	20 ³ / ₄
2"	*	7 ¹ / ₄ "	2 ¹⁵ / ₁₆ "	3 ¹⁵ / ₁₆ "	5 ³ / ₄ "	20 ¹ / ₄
	**	8 ³ / ₈ "	2 ¹⁵ / ₁₆ "	3 ¹⁵ / ₁₆ "	5 ³ / ₄ "	20 ³ / ₄

- * Air
- ** Water

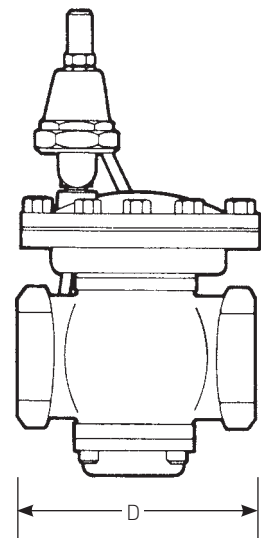
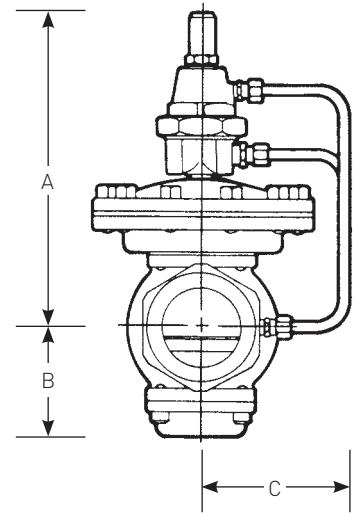

CASH VALVE TYPE KP BACK PRESSURE VALVES

SPECIFICATIONS

Inlet pressure (psi)	Inlet pressure rise*	Capacity information							
		Water flow (gpm)				Air flow (scfm)			
		1"	1¼"	1½"	2"	1"	1¼"	1½"	2"
15	5%	25	25	45	45	162	180	500	560
	10%	30	35	60	60	182	200	540	600
	20%	35	50	95	95	210	235	575	640
25	5%	35	35	60	60	225	250	735	820
	10%	40	50	80	80	265	295	800	890
	20%	40	70	125	125	295	330	890	990
50	5%	40	60	85	85	405	450	1260	1400
	10%	50	70	105	105	435	485	1300	1450
	20%	50	90	130	155	460	515	1365	1520
75	5%	50	70	100	100	540	600	1590	1770
	10%	50	90	125	125	550	610	1635	1820
	20%	50	90	130	180	575	640	1710	1900
100	5%	50	90	120	120	615	685	1820	2020
	10%	50	90	130	150	635	707	1890	2100
	20%	50	90	130	210	660	735	1980	2200
125	5%	50	90	130	135	688	765	2030	2260
	10%	50	90	130	180	710	790	2125	2360
	20%	50	90	130	210	745	830	2215	2460
150	5%	50	90	130	160	760	845	2250	2500
	10%	50	90	130	210	780	870	2320	2580
	20%	50	90	130	210	815	905	2410	2680
200	5%	50	90	130	200	855	950	2565	2850
	10%	50	90	130	210	875	975	2610	2900
	20%	50	90	130	210	920	1020	2700	3010

Note: flows are based on valve discharge to atmosphere or to an atmospheric pressure return line. If the valve discharge pressure is higher than 5 psi, consult the factory for capacity information.

* Inlet pressure rise is defined as the increase in inlet pressure required to pass a given flow, shown here as a percentage. For example: The size of KP valve required to pass 70 gpm at a set pressure of 50 psi and a maximum allowable overpressure to 55 psi (10% rise), based on the table above, would be a 1¼" KP valve.

CASH VALVE TYPE KP BACK PRESSURE VALVES

SPECIFICATIONS

Typical performance curves

The performance curves shown are for a 2" (50 mm) Type KP for water service at pressure settings of 75, 100 and 150 psi (5.2, 6.9 and 10.34 barg). These flow curves clearly show the exceptional control offered by the Type KP; there is very little change in pressure from minimum to maximum flow. For example, a 2" (50 mm) KP with a 100 psi (6.9 barg) pressure setting will pass 120 gpm (454 l/min) with only a 5% rise in pressure (to 105 psi (7.2 barg)).

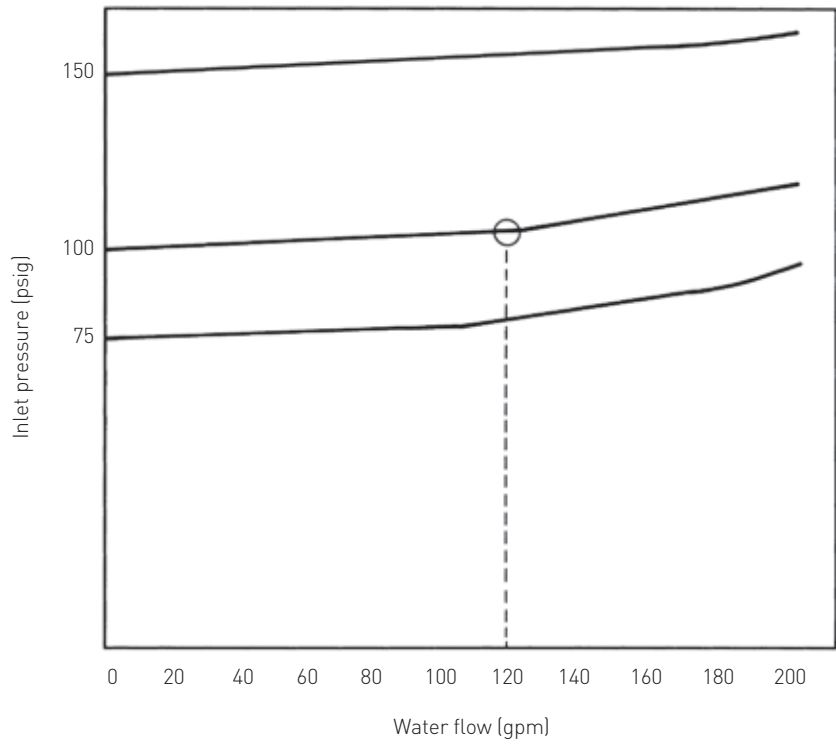

TYPICAL PERFORMANCE CURVE PRESSURE - 2" TYPE KP VALVE SHOWN

CASH VALVE TYPE KP BACK PRESSURE VALVES

SELECTION GUIDE

Example:	KP	E	W	S	B	F	01	-	E	0005
Model										
KP	KP (pilot operated BPV)									
Valve size										
E	1"									
F	1¼"									
G	1½"									
H	2"									
Service										
W	Water									
A	Air									
T	High temperature water/air									
O	Oxygen gas									
P	High pressure water/air									
Body/connection style										
S	Side inlet/side outlet – straight through w/NPT connections									
Seat material										
B	NBR (water/air)									
V	FKM (O ₂ gas service or water/air high temperature)									
S	Silicone (water/air high pressure)									
Pressure screw style										
S	Standard									
Variation										
01	Catalog standard									
02	Air/O ₂ gas service vented downstream									
Design revision										
(-)	Original design									
Spring material										
E	Stainless steel									
Set pressure										
0015	15 psig									
0100	100 psig									

SPRING RANGES

Service	Spring mtl	Range	Remarks
W, A, T		15 - 65	
W, A, T		50 - 200	
P		0 - 30	400° max temp
P	E	31 - 50	400° max temp
P		51 - 80	400° max temp
P		81 - 150	400° max temp
P		151 - 260	400° max temp
O		40 - 100	

