



## CASH VALVES LS SERIES PRESSURE REDUCING AND REGULATING VALVES

High pressure single-seated, spring loaded, direct acting diaphragm type regulators for inlet pressures to 2400 psig (165.5 barg)



### FEATURES

- Automatically reduce high inlet pressures to lower outlet pressures within close limits regardless of fluctuations.
- Designed for use on air, water, oil, oxygen, carbon-dioxide and other gases and fluids.
- Designed and built to meet the rugged requirements of high pressure regulation and reduction.
- Exceptional flow characteristics.
- Stainless steel piston/piston assemblies, cylinders, seat ring and strainer screens as standard.
- NBR diaphragm and O-rings.
- Self-renewable seat ring is simply flipped over and re-installed rather than replaced.
- NPTF 'Dryseal' threaded ends as standard.
- Closing cap or T-handle adjusting screw options available.

### GENERAL APPLICATION

Type LS Series regulators are recommended for use on high pressure test rigs and pressure vessel or casting test equipment, hydraulic cylinders and air tanks. Also available for cryogenic service.

### TECHNICAL DATA

Materials:	Bronze
Sizes:	3/8", 1/2", 3/4" (10.5, 15, 19 mm)
Connections:	Threaded NPTF
Inlet pressure range:	500 to 2400 psig (34.5 to 165.5 barg)
Reduced pressure range:	40 to 500 psig (2.8 to 34.5 barg)
Temperature range:	-320° to 180°F (-195° to 82°C)

# CASH VALVES LS SERIES PRESSURE REDUCING AND REGULATING VALVES

## MODELS OVERVIEW

All LS Series valves are designed and built to meet the rugged requirements of a high pressure regulating and reducing valve with a bronze body, spring chamber and bottom plug. Four versions are available:

**Type LS-1** has a metal seat piston and cylinder particularly designed for high or low temperature and high pressure drop applications.

**Type LS-2** has an NBR seat and balanced piston design for applications requiring higher capacities and/or tight shut-off. The balanced design assures close control regardless of inlet pressure fluctuations.

**Type LS-3** is furnished with a modified cylinder and no strainer screen for applications involving heavy or high viscosity fluids.

**Type LS-4** is constructed for cryogenic service to -320°F (-195°C).

**Special note:** although the metal to metal seat in the Types LS-1 and LS-3 is stainless steel, which assures maximum seat life and good closure, it will not shut-off drip tight. For installations requiring a definite pressure maximum on the downstream side, it is recommended that a Cash Valve Type FR back pressure valve is installed close to the outlet of the Types LS-1 or LS-3 regulators. For full information on the Type FR see data sheet VCTDS-00516.

## OPTIONS

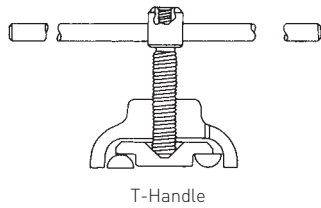
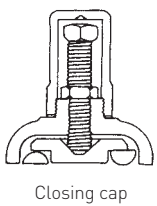

## LS INTERIOR DETAILS

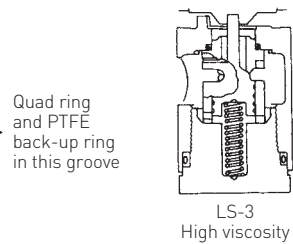
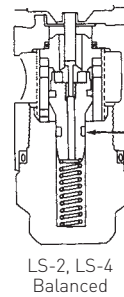
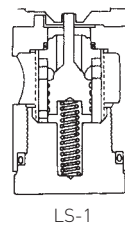

Quad ring and PTFE back-up ring in this groove

## SPECIFICATIONS

### TYPE LS-1

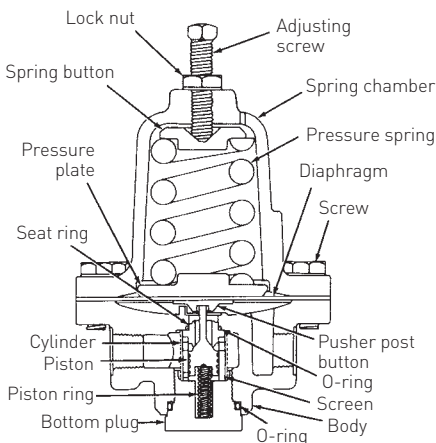

### TYPE LS-2, TYPE LS-4

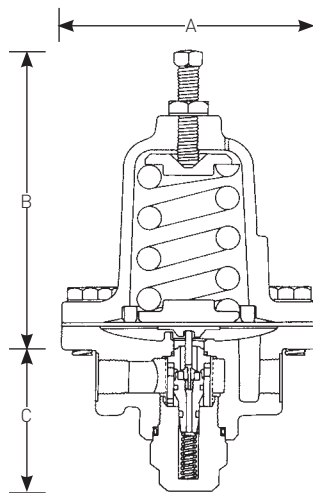

### TYPE LS-3

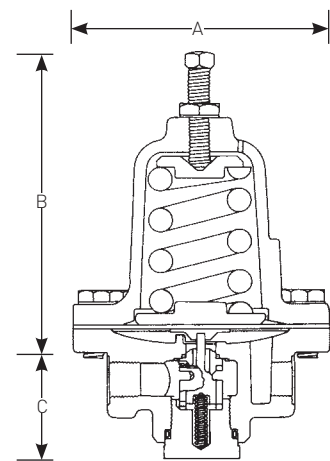

## DIMENSIONS

Type	Size	Dimensions, inches					Ship. wt. lbs.
		A	B <sup>[1]</sup>	B <sup>[2]</sup>	B <sup>[3]</sup>	C	
LS-1	All	5 <sup>7</sup> / <sub>8</sub> "	7 <sup>1</sup> / <sub>2</sub> "	7 <sup>5</sup> / <sub>8</sub> "	8 <sup>5</sup> / <sub>8</sub> "	1 <sup>13</sup> / <sub>16</sub> "	20
LS-3	All	5 <sup>7</sup> / <sub>8</sub> "	7 <sup>1</sup> / <sub>2</sub> "	7 <sup>5</sup> / <sub>8</sub> "	8 <sup>5</sup> / <sub>8</sub> "	1 <sup>13</sup> / <sub>16</sub> "	20
LS-2	All	5 <sup>7</sup> / <sub>8</sub> "	7 <sup>1</sup> / <sub>2</sub> "	7 <sup>5</sup> / <sub>8</sub> "	8 <sup>5</sup> / <sub>8</sub> "	2 <sup>5</sup> / <sub>8</sub> "	20
LS-4	All	5 <sup>7</sup> / <sub>8</sub> "	7 <sup>1</sup> / <sub>2</sub> "	7 <sup>5</sup> / <sub>8</sub> "	8 <sup>5</sup> / <sub>8</sub> "	2 <sup>5</sup> / <sub>8</sub> "	20

## NOTES

1. With standard adjusting screw.
2. With closing cap.
3. With T-handle adjusting screw.

# CASH VALVES LS SERIES PRESSURE REDUCING AND REGULATING VALVES

## SPECIFICATIONS - CAPACITIES (ALL SIZES\*)

Inlet pressure (psig)	Outlet pressure (psig)	Water capacity GPM			Air capacity SCFM		
		5% Fall-off	10% Fall-off	15% Fall-off	5% Fall-off	10% Fall-off	15% Fall-off
500	400	5	10	15	63	126	189
	250	6	12	18	74	148	222
	150	6	12	18	74	148	222
	100	6	12	18	74	148	222
750	500	7	14	21	105	210	325
	300	8	16	24	109	218	327
	150	9	18	27	109	218	327
	100	9	18	27	109	218	327
1000	750	7	14	21	135	270	405
	500	9	18	27	138	276	414
	300	10	20	30	138	276	414
	100	10	20	30	138	276	414
1500	750	11	22	33	220	440	660
	500	12	24	36	220	440	660
	300	13	26	39	220	440	660
	150	14	28	42	220	440	660
2000	750	14	28	42	293	586	879
	500	15	30	45	293	586	879
	300	16	32	48	293	586	879
	200	17	34	51	293	586	879
2400	750	17	33	50	351	703	1054
	500	18	35	53	351	703	1054
	300	19	37	56	351	703	1054
	200	20	39	59	351	703	1054

\* The above data reflects regulator flow capacities, in some cases this capacity may represent flow velocities which exceed recommended piping practices.

## PRESSURE RANGES

Type	Sizes	Max. working range, psi
LS-1	3/8", 1/2" or 3/4"	40-200
LS-2	3/8", 1/2" or 3/4"	40-350
LS-3	3/8", 1/2" or 3/4"	40-500
LS-4	3/8", 1/2" or 3/4"	40-500

\* High pressure range (400-750 psi for LS-1, -2, -3 only) requires internal modification at additional cost, consult the factory.

TYPE LS-1, TYPE LS-3



TYPE LS-2, TYPE LS-4



# CASH VALVES LS SERIES PRESSURE REDUCING AND REGULATING VALVES

## SELECTION GUIDE

Example:	LS1	B	S	B	S	01	-	D	0040
<b>Model</b>									
<b>LS1</b>	LS-1 (metal to metal seat)								
<b>LS2</b>	LS-2 (PTFE soft seat)								
<b>LS3</b>	LS-3 (metal to metal for heavy fluids)								
<b>LS4</b>	LS-4 (PTFE soft seat for cryogenic service)								
<b>Valve size</b>									
<b>B</b>	3/8"								
<b>C</b>	1/2"								
<b>D</b>	3/4"								
<b>Spring chamber style</b>									
<b>S</b>	Standard								
<b>C</b>	With adjusting screw cap								
<b>Diaphragm material</b>									
<b>B</b>	NBR (LS-1; LS-2; LS-3)								
<b>Z</b>	Bronze (LS-1, LS-2, LS-3, LS-4)								
<b>V</b>	FKM (LS-1; LS-2; LS-3)								
<b>Pressure screw style</b>									
<b>S</b>	Standard								
<b>T</b>	T-handle (LS-1; LS-2; LS-3)								
<b>Variation</b>									
<b>01</b>	Standard (NBR O-rings LS-1, LS-2, LS-3), PTFE O-rings (LS-4)								
<b>02</b>	FKM O-rings (LS-1, LS-2, LS-3)								
<b>03</b>	PTFE O-rings (LS-1, LS-3)								
<b>11</b>	LS-2 w/non balanced piston and NBR O-rings								
<b>12</b>	LS-2 w/non balanced piston and FKM O-rings								
<b>13</b>	LS-2 w/non balanced piston and PTFE O-rings								
<b>Design revision</b>									
<b>[-]</b>	Indicates original design								
<b>Spring material</b>									
<b>D</b>	Carbon steel (LS-1, LS-2, LS-3 only)								
<b>E</b>	Stainless steel (LS-4 only)								
<b>Set pressure</b>									
<b>0040</b>	40 psig								
<b>0125</b>	125 psig								
<b>0300</b>	300 psig								

## STANDARD SPRING RANGES - MUST SPECIFY DURING ORDER PROCESS

LS (*)	40-200	40-350	40-500	400-750
LS (**)	40-500			

## NOTES

(\*) Steel

(\*\*) Stainless steel